

# APFC-116

## AUTOMATIC POWER FACTOR CONTROLLER

### (1- CT Based APFC Relay)



## TECH SPECS

Dimension (HxWxD) mm	144 x 144 x 80
Panel Cutout	137 x 137
Input Current Range	10mA to 5Amp AC (Without CT) (CT Ratio Selectable 5/5A AC to 9999/5A) for Main CT & Capacitor CT
Min. Operating Current For Working of APFC	Selectable range 1mA to 500mA (By Default 30mA)
Input Voltage Range	300 to 520 V AC (P-P) CAT III
Set Target PF	-1.000 (Lead) To 1.000 (Lag)
Power Supply	300V to 520V AC , 50Hz

## APPLICATIONS

- PF Management using 1 CT Method
- For 3 Phase Balanced Industrial Loads
- Energy Monitoring System
- DG Set Panels
- Power Factor Correction Panels
- Commercial Buildings

# Technical Specifications

## Meter type

3Phase 3Wire	2 Phase of Voltage & Current Of Remaining Phase
--------------	---

## Auxiliary Power Supply

Power Supply	300 to 520 V AC ,50 Hz
Burden	Approx 10VA

## Signal Input Parameter

Input Voltage AC	300 to 520V AC (L-L)
Current AC (1 CT Sensing)	5 to 9999Amp Selectable
Primary CT Ratio	
Secondary Current AC	10mA to 5Amp (Without CT)
Capacitor CT Ratio	5 to 9999Amp Selectable
Capacitor & Main CT Over Load	6A

## Display & Keys

Display	Upper: 4 Digit,7 seg,0.60"White Lower: 7 Digit,7 seg,0.38"Green
Key	SET/ENT, UP, DOWN, EXIT
LED Indication	Amp, Volt, Set CosØ, PF, Mode, Manual, Intel, Fan, Kvar, Quadrant, Capacitive, Inductive, Tune Symbol

## Memory

Memory Retention	10 Years
------------------	----------

## Accuracy

Class 0.5 ( Standard )

## Output

### Relay

- ▶ 16 Relay with 1 NO-C for capacitor bank
- ▶ Switching Voltage :- 250V AC
- ▶ Current (Resistive load) :- 5A
- ▶ Expected Electrical Life :- 2,00,000 Operation
- ▶ Expected Mechanical Life :- 5,00,0000 Operation Min

## Calculated Parameters

Voltage	$V_{LL}$ (Phase to Phase)
Current	▶ Main CT Current ▶ Capacitor CT Current
Power Factor	-1.000 (Lead) to 1.000 (Lag)

## Dimensions

Bezel	144 X 144mm
Panel Cutout	137 X 137mm
Depth of Installation	80 mm

## Setting Parameter

Set COSØ	-1.000 (Lead) to 1.000 (Lag)
Scan Time	1 to 999.9 Second
Hysteresis	0 to 25 KVAR
Operating Mode	Manual, KVAR, Intel
Capacitor Bank Sensing	Manual / Capacitor CT

## Mechanical Dimension

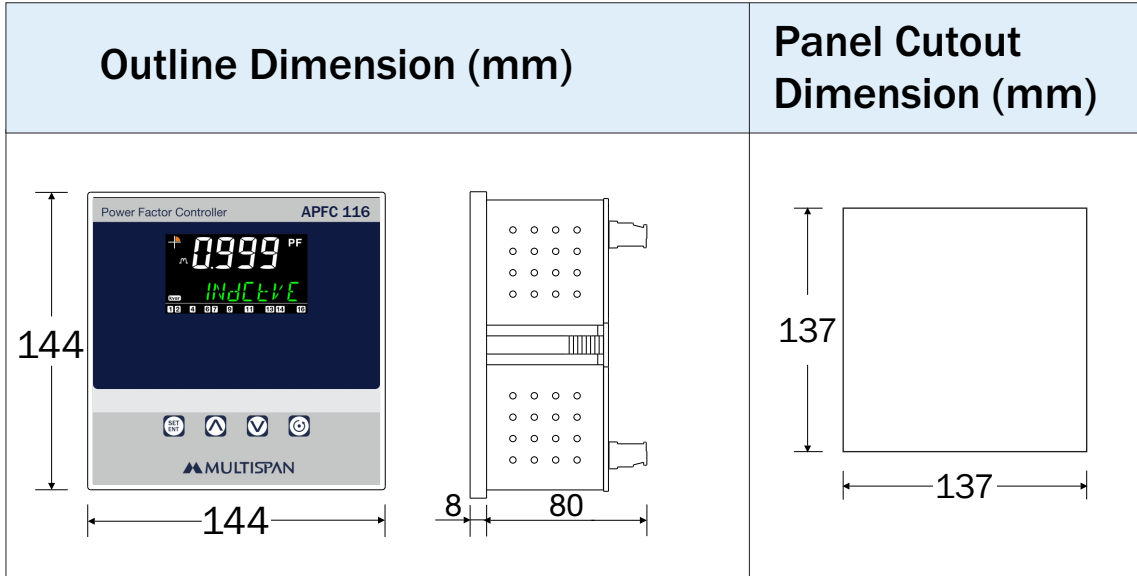

## Connection Diagram

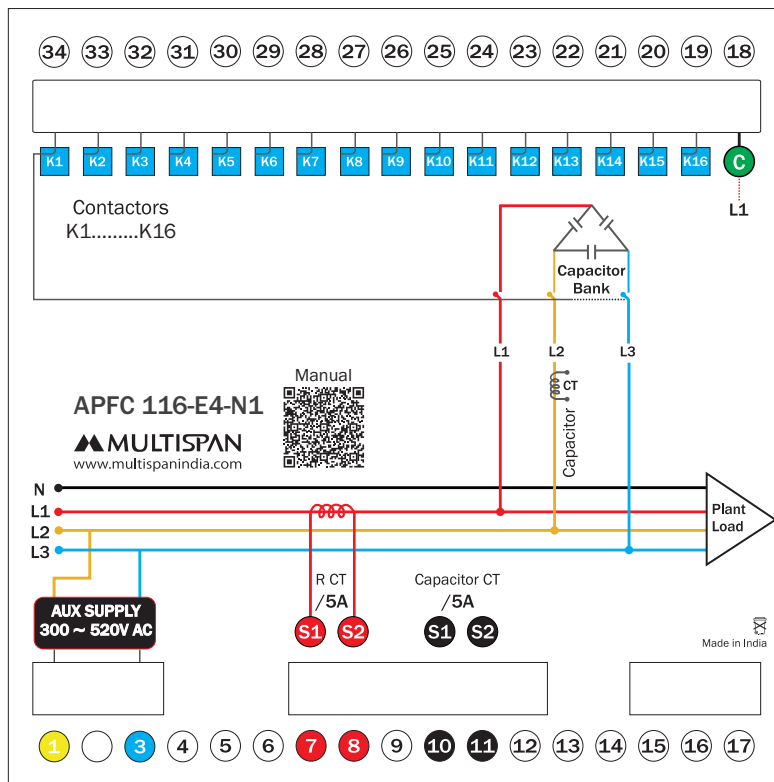

We reserve the right to change specifications without prior notice. Printing and typographical errors reserved.

Product improvement and upgrade is a constant procedure. So for more updated operating information & support contact us on 011-689-5700.