



Condition Monitoring

Telik Geter

Johannesburg Branch
MIMIC COMPONENTS
 Cape Town Branch
 Mimic Cape



Asset Condition Monitoring

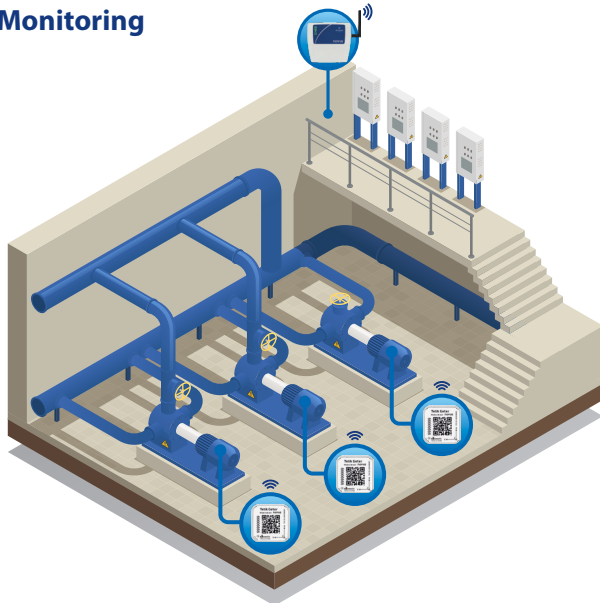

LONG BATTERY LIFE

Up to 10 years on battery



REMOTE MONITORING

No more manual inspection rounds



LONG-RANGE COMMUNICATION

Up to 50 m (line of sight, no obstacles)



COMPLETE VIBRATION ANALYSIS

RMS, VRMS, FFT, and raw signal for advanced diagnostics



HIGH SAMPLING RATE

Readings at intervals as fast as 1 second

- Detect anomalies early and reduce unplanned downtime with 24/7 asset condition monitoring and configurable alarms
- Complete vibration analysis: RMS, VRMS, FFT, and raw signal for advanced diagnostics
- Turn sensor signals into actionable insights with dashboards, trends, alarms and reports in the Novus Geter platform
- Built for industrial operations: scalable from a few critical machines to an entire plant, with structured asset organization and user management

NOVUS

We Measure, We Control, We Record

Technical Specifications

| Telik Geter Sensor | | |
|----------------------------------|-----------------------|------------------|
| OPERATION AND STORAGE CONDITIONS | Operating temperature | -20 °C ... 70 °C |
| | Storage temperature | -5 °C ... 25 °C |

| | | |
|----------------|--|---|
| HARDWARE | External dimensions | 25 mm x 40 mm x 40 mm |
| | Microcontroller | 32-Bit microcontroller, 16 MHz (ARM® Cortex™-M0) |
| | Memory | Flash memory: 256 kB RAM memory: 32 kB |
| | Communication | Bluetooth Low Energy 4.2 (2.4 GHz) |
| | Signal range | From 50 to 70 meters without obstacles |
| | Transmission power | +4 dBm |
| | Reception sensitivity | -93 dBm |
| | Battery | 2 x ER14250 (duration 9 to 60 months, according to the application) |
| | Fixing | 4 neodymium magnets 10 mm x 6 mm |
| | Encapsulation | Polycarbonate |
| | Embedded temperature sensor operation | -20 °C ... 85 °C |
| | Resolution of the embedded temperature sensor | 0.25 °C |
| | Temperature accuracy | ±4 °C without calibration |
| | Protection index | IP69K |
| Certifications | ANATEL: 13848-23-07089 FCC: FCC ID: 2AXVWN01 CE | |

| Airgate Geter Gateway | | |
|----------------------------------|-----------------------|------------------|
| OPERATION AND STORAGE CONDITIONS | Operating temperature | -20 °C ... 60 °C |
| | Storage temperature | -5 °C ... 25 °C |

| | | |
|-------------------------|------------------------------|---|
| COMMUNICATION INTERFACE | SouthBound | Bluetooth Low Energy 5.0 |
| | NorthBound | Ethernet 10/100 Mb/s, IEEE standard 802.3, and Wi-Fi 802.11 b/g/n 2.4 GHz |
| | Cloud communication protocol | MQTT and REST |
| | RS485 | For configuration purposes only |

| | | |
|----------|--------------------------|--|
| HARDWARE | External dimensions | 142 mm x 129 mm x 38 mm |
| | Power supply | 5 Vdc or 12 ~ 24 Vdc |
| | Power supply input | Detachable terminal blocks |
| | Power output | 5 Vdc auxiliary output |
| | Communication | Bluetooth Low Energy 4.2 (2.4 GHz – External antenna) |
| | Bluetooth signal range | From 50 to 70 meters without obstacles |
| | Transmission power | +8 dBm |
| | Reception sensitivity | -103 dBm |
| | Assembly | DIN rail or screw |
| | Housing | ABS + PC |
| | External antenna for BLE | SMA connector (2.4 GHz) |
| | Certifications | ANATEL: 13878-23-07089 FCC: Contains Wi-Fi module, FCC ID: 2AC7Z-ESPWROOM32D Contains BLE module, FCC ID: 2ABU6-MS88SF2 ISED: Contains Wi-Fi module, IC: 21098-ESPWROOM32D CE |

Johannesburg Branch

Cape Town Branch
 **Mimic Cape**



**TELIK GETER SOLUTION:
AIRGATE GETER GATEWAY
TELIK GETER SENSOR
USER GUIDE – V1.0x A**





| | | |
|----------|--|-----------|
| 1 | SAFETY ALERTS | 4 |
| 2 | PRESENTATION | 5 |
| 2.1 | AIRGATE GETER GATEWAY | 5 |
| 2.1.1 | APPLICATIONS..... | 5 |
| 2.1.2 | BENEFITS | 5 |
| 2.2 | TELIK GETER SENSOR | 5 |
| 2.2.1 | BENEFITS | 5 |
| 3 | DIMENSIONS | 7 |
| 3.1 | AIRGATE GETER GATEWAY..... | 7 |
| 3.2 | TELIK GETER SENSOR | 8 |
| 4 | INSTALLATION | 9 |
| 4.1 | MECHANICAL INSTALLATION..... | 9 |
| 4.1.1 | AIRGATE GETER GATEWAY | 9 |
| 4.1.2 | TELIK GETER SENSOR | 9 |
| 4.2 | ELECTRICAL INSTALLATION | 10 |
| 4.2.1 | AIRGATE GETER GATEWAY | 10 |
| 4.2.2 | INSTALLATION RECOMMENDATIONS | 10 |
| 4.2.3 | POWER SUPPLY | 10 |
| 4.3 | AIRGATE GETER GATEWAY: LED INDICATORS..... | 11 |
| 4.4 | AIRGATE GETER GATEWAY: RESET BUTTON..... | 11 |
| 4.5 | INSTALLATION RECOMMENDATIONS..... | 12 |
| 4.5.1 | PURPOSE | 12 |
| 4.5.2 | BEST PRACTICES FOR INDUSTRIAL INSTALLATION | 12 |
| 4.5.2.1 | AIRGATE GETER GATEWAY: INSTALLATION RECOMMENDATIONS | 12 |
| 4.5.2.2 | GROUNDED POWER SUPPLY | 12 |
| 5 | AIRGATE GETER GATEWAY: COMMUNICATION INTERFACES | 13 |
| 5.1 | USB INTERFACE | 13 |
| 5.2 | RS485 INTERFACE | 13 |
| 5.3 | ETHERNET INTERFACE | 14 |
| 5.4 | WI-FI INTERFACE..... | 14 |
| 5.5 | FRONTAL USB PORT..... | 14 |
| 6 | TELIK GETER SENSOR: EMBEDDED SERVICES | 15 |
| 6.1 | RMS VELOCITY (mm/s)..... | 15 |
| 6.2 | RMS ACCELERATION (m/s ²)..... | 15 |
| 6.3 | STATIC INCLINOMETER (°)..... | 15 |
| 6.4 | FAST FOURIER TRANSFORM (m/s ²) | 16 |
| 6.5 | RAW ACCELERATION (m/s ²)..... | 16 |
| 6.6 | TEMPERATURE (°C)..... | 16 |
| 6.7 | TELIK GETER SENSOR: SERVICES CONFIGURATION PARAMETERS | 17 |
| 6.7.1 | ACQUISITIONS BY SUBMISSION..... | 17 |
| 6.7.2 | RESOLUTION..... | 17 |
| 6.7.3 | SENSITIVITY | 17 |
| 6.7.4 | AXIS..... | 17 |
| 6.7.5 | FREQUENCY | 17 |
| 6.7.6 | NUMBER OF SAMPLES | 17 |
| 6.7.7 | INTERVAL BETWEEN ACQUISITIONS..... | 18 |
| 6.7.8 | LOW AND HIGH FREQUENCY..... | 18 |
| 6.7.9 | CHANNEL..... | 18 |
| 7 | AIRGATE GETER GATEWAY: SETTINGS | 19 |

| | | |
|-----------|--|-----------|
| 8 | DATA VISUALIZATION AND STORAGE VIA NOVUS GETER..... | 20 |
| 9 | TECHNICAL SPECIFICATION | 21 |
| 9.1 | AIRGATE GETER GATEWAY..... | 21 |
| 9.2 | TELIK GETER SENSOR | 21 |
| 9.3 | CERTIFICATIONS | 22 |
| 10 | WARRANTY..... | 23 |

1 SAFETY ALERTS

The symbols below are used throughout this manual to draw the user's attention to valuable information related to device safety and use.

| | | |
|---|---|--|
|  |  |  |
| CAUTION Read the manual fully before installing and operating the device. | CAUTION OR HAZARD Risk of electric shock. | ATTENTION Electrostatic-sensitive device. Make sure you take the necessary precautions before handling it. |

Safety recommendations must be followed to ensure personal safety and prevent damage to the equipment or system. If the equipment is used in a manner other than that specified in this manual, the safety precautions may not be effective.

2.1 AIRGATE GETER GATEWAY

The **AirGate Geter Gateway** was designed to enable data collection in harsh industrial environments. Networks established with multiple **AirGate Geter Gateways** can collect data and send configuration commands to any **Telik Geter Smart Sensor** within range. In addition, they provide information on the received signal strength of each message, enabling sensor mobility and asset location.

The **AirGate Geter Gateway** uses the MQTT protocol to send data to **NOVUS Geter**, where it can be stored, processed, and delivered in real time to any cloud-based application via data streaming APIs.

The **AirGate Geter Gateway** can be powered by 5 Vdc or 12 ~ 24 Vdc supplies. It can be mounted on a DIN rail or secured with screws.

The external antenna with SMA connector allows you to install the Gateway inside metal enclosures while positioning the antenna externally, increasing the coverage area of each unit.

2.1.1 APPLICATIONS

AirGate Geter Gateways are used to provide a robust and dynamic communication infrastructure with **Telik Geter Smart Sensors**, enabling several Industry 4.0 projects, such as:

- Sensing for predictive maintenance of electric motors.
- Vibration trend analysis.
- Hour-metering for machines and electric motors.
- Motor stall detection.
- Cavitation detection in pumps.
- Gearboxes monitoring.
- Surface temperature sensing.
- Motor location and identification, as well as maintenance history.
- Monitoring of door and gate opening/closing.
- 3-axis inclinometer.
- Pipeline vibration monitoring.
- Motion detection.
- Valve and lever inclination.
- Workplace ergonomics monitoring.
- Storage levels.
- Transformer monitoring.

2.1.2 BENEFITS

- Low cost.
- Easy installation.
- External antenna that allows the use of extensions.
- Data collection from up to 512 sensors simultaneously.
- Dynamic network enabling free sensor movement.
- Secure connection via Wi-Fi or Ethernet.
- Enables sensor and asset location.
- Operation of each independent collector in the network.

2.2 TELIK GETER SENSOR

The **Telik Geter Sensor** is an Internet of Things–based solution designed to enable the digitalization of industrial processes and machines. It is a wireless sensor that acquires temperature and vibration data, operating as a signal driver that transmits data to the cloud in real time.

The **Telik Geter Sensor** is powered by 2 ER14250 batteries, providing up to 5 years of autonomy. The **Telik Geter Sensor** is mounted on motors using neodymium magnets. Its plastic enclosure is designed to withstand industrial environments.

The sensor interface applications allow direct access to the operating settings of the MEMS accelerometer and its peripherals, such as data acquisition frequency, measurement resolution, resolution and sensitivity of the embedded algorithms, making it highly flexible for a wide range of applications.

2.2.1 BENEFITS

- Low cost.
- Low battery consumption.
- Easy installation.
- Wireless and magnetically attached housing.
- Compact and resistant housing.
- Flexible applications with parameterizable analyses.
- Increased reliability and faster decision-making for predictive maintenance.

- Reduced maintenance costs.
- Reduced unscheduled downtime.
- Data centralization.

3 DIMENSIONS

3.1 AIRGATE GETER GATEWAY

AirGate Geter Gateway has the following dimensions:

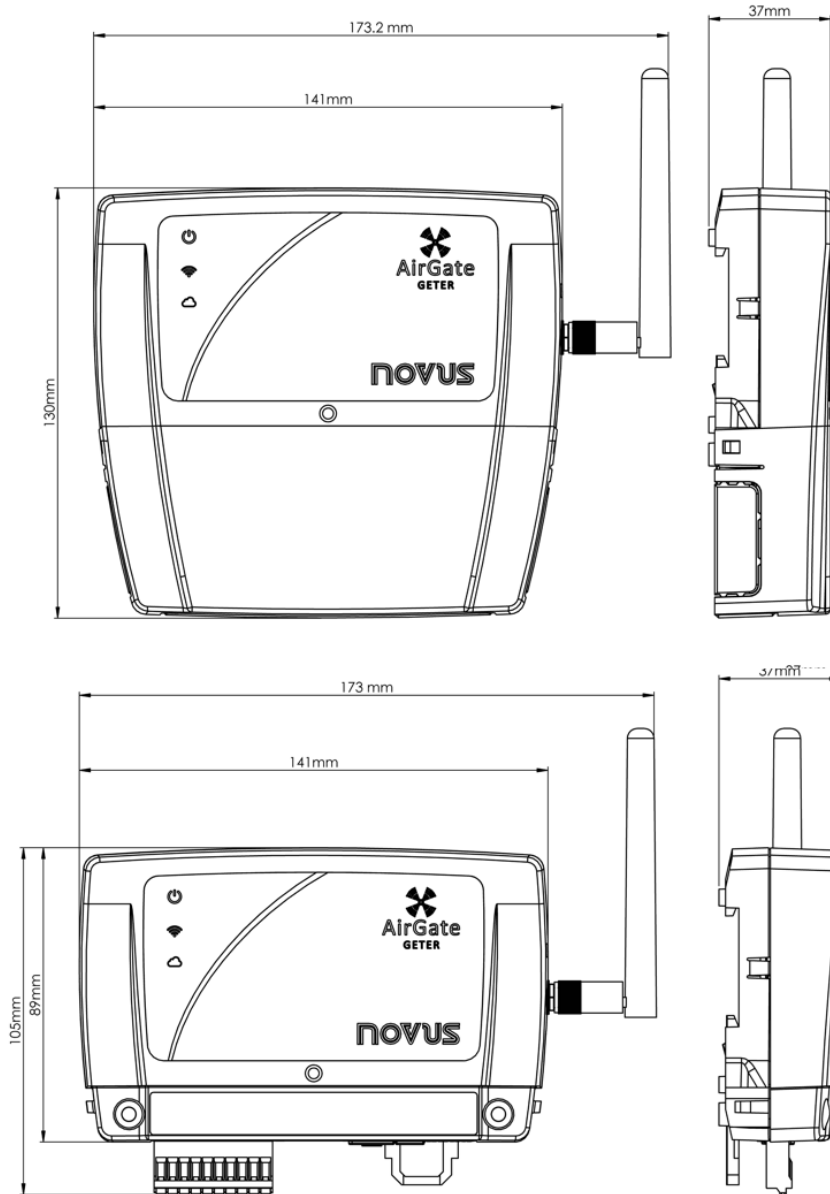

Figure 1

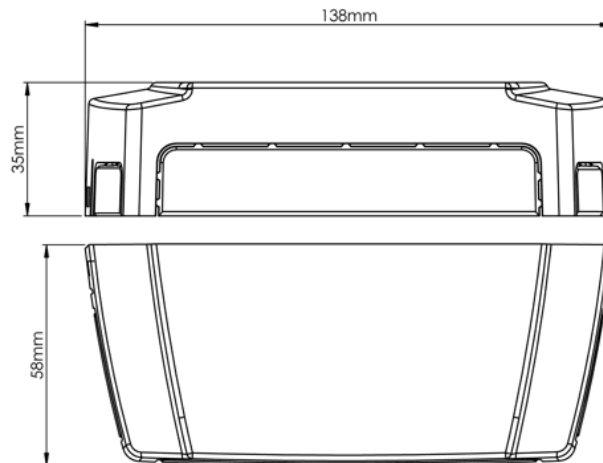

Figure 2

3.2 TELIK GETER SENSOR

Telik Geter Sensor has the following dimensions:

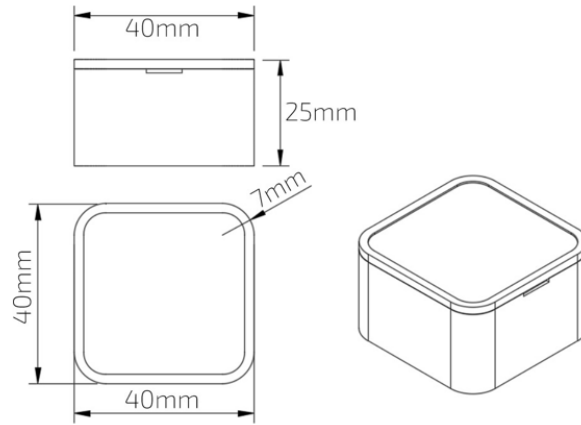

Figure 3

4 INSTALLATION

4.1 MECHANICAL INSTALLATION

4.1.1 AIRGATE GETER GATEWAY

The **AirGate Geter Gateway** can be installed on a 35 mm DIN rail, as shown in the figure below:

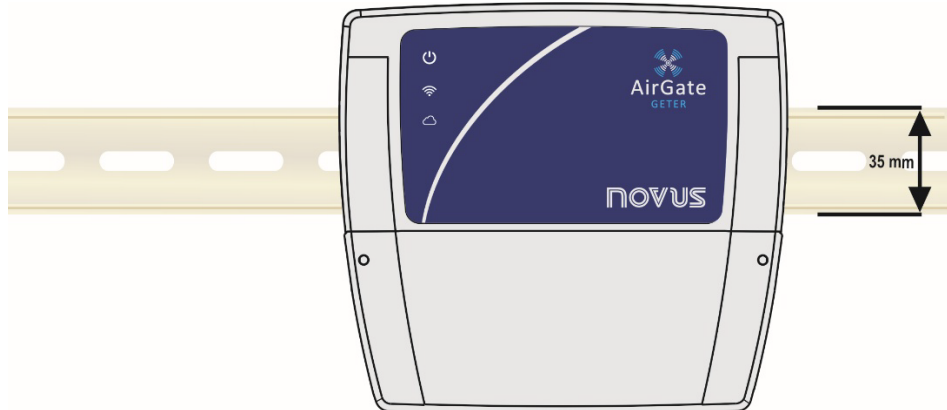

Figure 4

The device also has 2 holes, which allow it to be fixed with screws, as shown in the figure below:

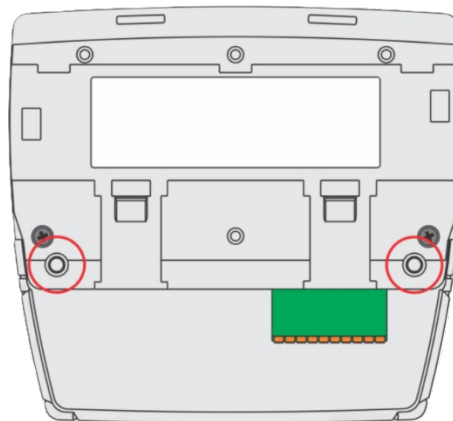

Figure 5

The **AirGate Geter Gateway** has a removable cover to protect the connection terminals. The protective cover has 3 detachable areas (1 at the bottom and 1 on each side), which makes it easier to pass the cables through:

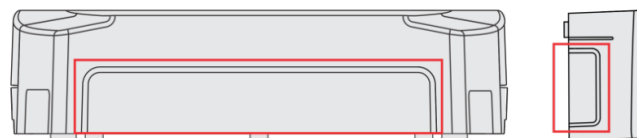

Figure 6

The protective cover has 2 pins, located on the sides of the housing, to make it easier to fit onto the body of the device. Once the cover has been installed, use a screwdriver to remove it.

When installing an **AirGate Geter Gateway** inside a panel, make sure that the panel material does not obstruct the propagation of Wi-Fi or Bluetooth signals. It is recommended to use a plastic or acrylic box. Otherwise, consider using Ethernet to connect to the local network, as well as an external antenna for Bluetooth.

4.1.2 TELIK GETER SENSOR

The **Telik Geter Sensor** has 4 neodymium magnets, which allow it to be installed on magnetic surfaces such as steel or cast iron. The high magnetization of the magnets and the mechanical design of the device allow it to remain fixed even in extreme operating conditions. To ensure proper mounting, it is important that the entire surface of the device is in contact with the installation surface.

If the installation surface is not magnetic, the device can be glued with adhesives suitable for polycarbonate. It is also possible to attach a magnetic metal plate to the surface. This second option has the advantage of not compromising the mobility of the **Telik Geter Sensor**.

4.2 ELECTRICAL INSTALLATION

4.2.1 AIRGATE GETER GATEWAY

The AirGate Geter Gateway has a detachable connection terminal for connecting the external power supply, as shown in the figure below:

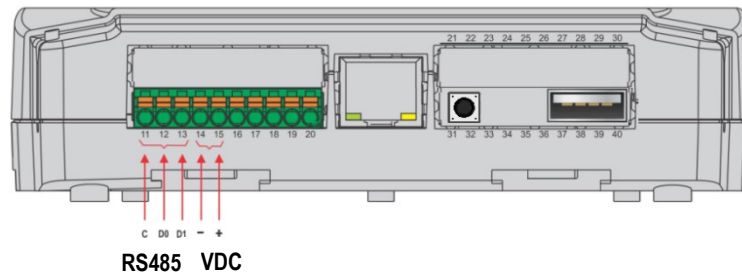

Figure 7

To connect the wires, it is recommended to remove the device's connection terminals and observe the numbering engraved on the housing.



The inputs, outputs, and communication interfaces of this device are not isolated from the power supply or from each other.

4.2.2 INSTALLATION RECOMMENDATIONS

- Electronic and analog signal conductors should run through the plant separately from the output and supply conductors. If possible, in grounded conduits.
- The power supply for electronic instruments must come from a network specific to the instrumentation.
- It is recommended to use RC FILTERS (noise suppressors) in contactor coils, solenoids, etc.
- In control applications, it is essential to consider what can happen when any part of the system fails. The internal safety features of the device do not guarantee full protection.
- You must detach the connection terminals before making the electrical connections. Before connecting them, make sure that the connections have been made correctly.

4.2.3 POWER SUPPLY

The power supply is connected to the terminals, as shown in the figure below. The power supply used must be a DC type, with a voltage between 8 and 30 V. It is possible to use 12 or 24 Vdc power supplies.

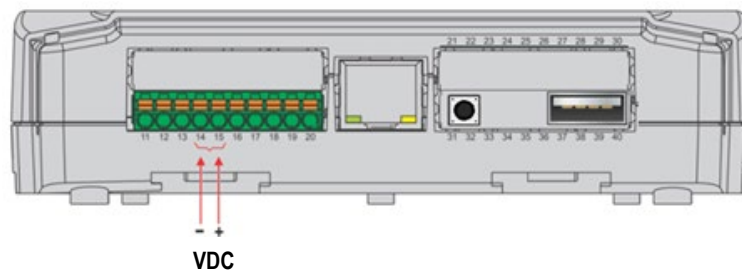

Figure 8

4.3 AIRGATE GETER GATEWAY: LED INDICATORS

The **AirGate Geter Gateway** has 3 LEDs, located at the front of the device, as shown in the figure below:

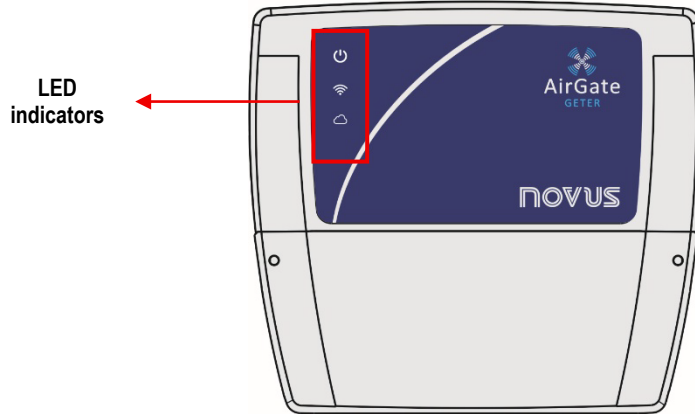

Figure 9

The **AirGate Geter Gateway** has the following indicators:

| NAME | SYMBOL | STATUS | DESCRIPTION |
|-------------------------|--------|----------|---|
| Status | 🔌 | Off | Device off. |
| | | On | Device on. |
| Wi-Fi | 📶 | Off | Device disconnected from the Wi-Fi network. |
| | | On | Device connected to the Wi-Fi network. |
| | | Flashing | Device ready to be installed. |
| Connection to the cloud | ☁️ | Off | Device disconnected from the server. |
| | | On | Device connected to the server. |
| | | Flashing | Device sending data to the cloud and updating the firmware. |

Table 1

4.4 AIRGATE GETER GATEWAY: RESET BUTTON

The **AirGate Geter Gateway** has a **Reset** button located near the Ethernet port, as shown in the figure below:

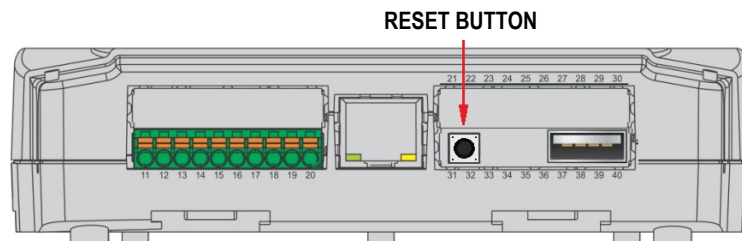

Figure 10

You can use this button to reset the device or to open the access point of your **AirGate Geter Gateway**. The open access point will follow the format «TELIK GETER XXXX», where XXXX is the last 4 bytes of the device's Wi-Fi MAC address (which is found on the back label).

To open the access point, simply press this button. This will cause the 📶 LED on the front of the device to start flashing. To reset the device, simply press and hold the button for 6 seconds. While the button is pressed, the LEDs will flash 5 times. When the LEDs remain lit, the button can be released. This will reset the device and delete the settings.

4.5 INSTALLATION RECOMMENDATIONS

4.5.1 PURPOSE

Due to the high levels of electromagnetic noise caused by machinery in industrial environments, digital devices can be susceptible to electromagnetic interference. Because of this, you should adopt good practices during the installation of electronic devices to mitigate the effects of this interference.

This section presents some recommendations for the installation of digital sensors and is intended to prevent data acquisition problems.

4.5.2 BEST PRACTICES FOR INDUSTRIAL INSTALLATION

A proper installation should include an industrial grounding system that complies with applicable ABNT technical standards, such as NBR 5410 and NBR 5419. This is necessary to ensure the dissipation of excessive noise generated by industrial machinery and to provide equipotential bonding between the supply voltages of electronic equipment.

Along with the grounding system, it is recommended to choose a good 24 VDC power supply to ensure isolation and noise filtering from the AC power input to the 24 VDC power output. Power supplies with CE Mark certification are the most suitable.

Some industrial plants contain machines that generate excessive electromagnetic noise. In such cases, it is recommended to use an instrumentation panel to install electronic equipment. This panel must comply with technical standards and provide shielding from the industrial environment through a grounding terminal, which must be connected to the grounding system.

An important recommendation for proper system operation is to ensure that cabling between sensors and instrumentation equipment follows the best possible routing within the industrial plant. This helps minimize the distance between instruments and sensors while keeping them away from potential sources of electromagnetic noise, such as machines, motors, and electromagnetic pulse sources.

It is recommended that instrumentation sensor cabling run through dedicated, grounded conduits exclusively for instrumentation. Power supply wiring for machinery should be routed through separate conduits.

4.5.2.1 AIRGATE GETER GATEWAY: INSTALLATION RECOMMENDATIONS

In most cases, following the best practices for industrial installation described in the previous section is sufficient to ensure that the system functions properly. However, depending on the environment where the equipment is installed, some additional recommendations may be necessary.

4.5.2.2 GROUNDED POWER SUPPLY

The figure below shows how to connect a power supply to an **AirGate Geter Gateway**. In this case, the power supply must be grounded.

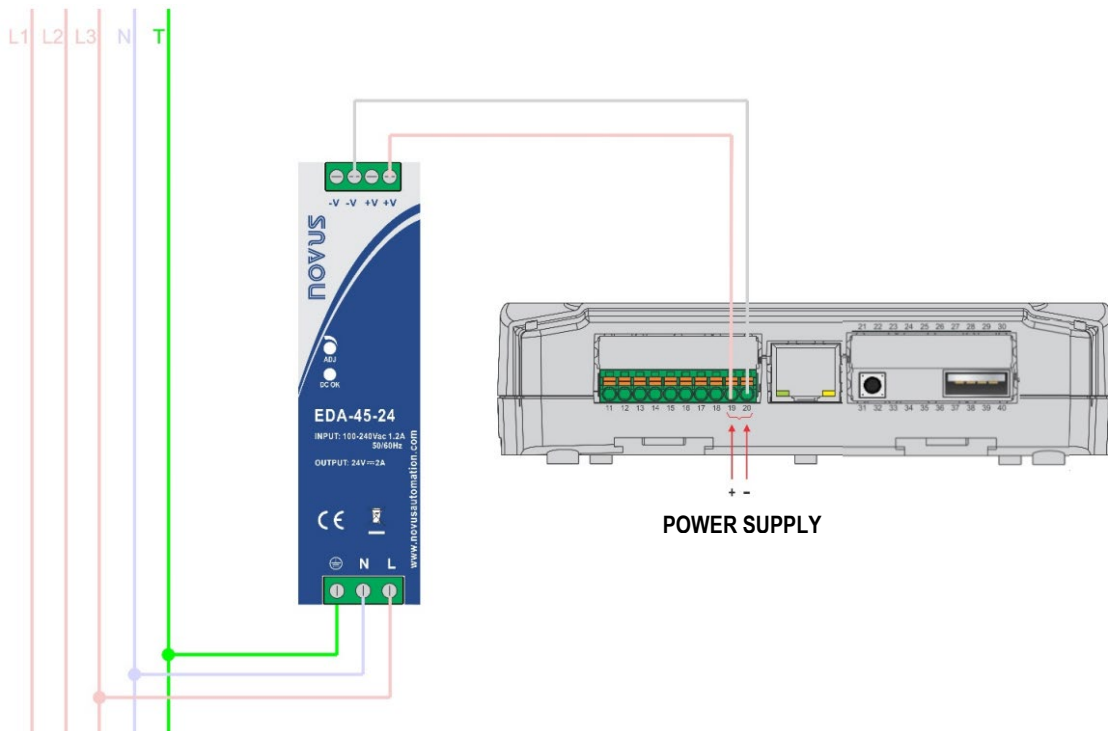

Figure 11

5 AIRGATE GETER GATEWAY: COMMUNICATION INTERFACES

5.1 USB INTERFACE

The **AirGate Geter Gateway** has 1 USB port located on the side of the housing. This interface is primarily intended for powering the device during configuration.

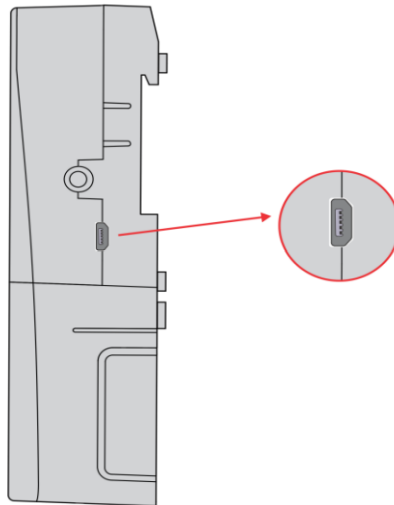

Figure 12



The USB interface is not isolated. Its purpose is temporary use during CONFIGURATION and MONITORING periods.

5.2 RS485 INTERFACE

You can obtain the IP addresses of the device's Ethernet and Wi-Fi interfaces via the RS485 connection. The connection interface is located on one of the detachable terminals of the **AirGate Geter Gateway**, as shown in the figure below:

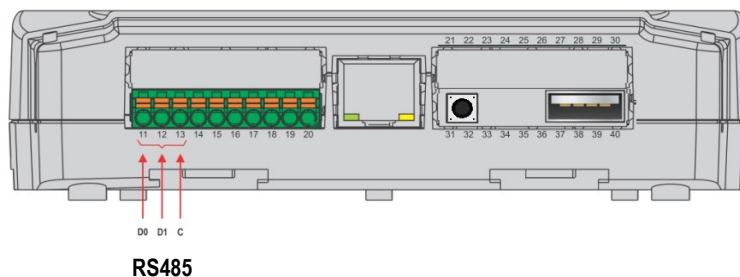

Figure 13

By default, the RS485 interface is configured to operate at a speed of 115200. To read the data, you must use the Modbus RTU protocol. The table below helps you set the RS485 communication interface:

| | | | | | |
|-----|-----------|----|--|-----------------------------------|-------------|
| D1 | D | D+ | B | Bidirectional data line. | Terminal 11 |
| D0 | \bar{D} | D- | A | Inverted bidirectional data line. | Terminal 12 |
| C | | | Optional connection that improves communication performance. | Terminal 13 | |
| GND | | | | | |

Table 2



The RS485 interface of the **AirGate Geter** features a 1/4 UL (Unit Load) class transceiver. According to the TIA/EIA-485 standard, this allows the hardware to support addressing of up to 128 devices on the same physical bus without the need for repeaters. The actual maximum number of devices in a network also depends on the Unit Load class of the other devices connected to the same bus.

More details about the implementation of a Modbus devices network via RS485 can be found in the document **Basic RS485 and RS422 Concepts**, available on the website www.novusautomation.com.

5.3 ETHERNET INTERFACE

The **AirGate Geter Gateway** has an Ethernet interface, located next to the terminals, as shown in the figure below:

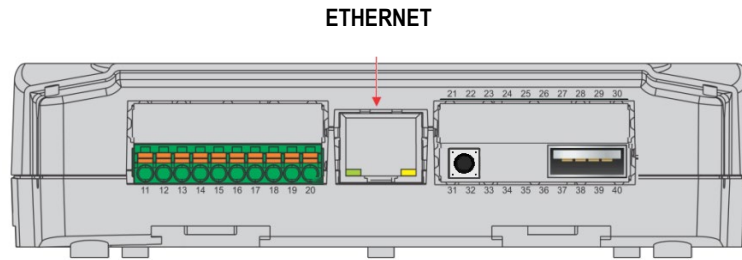



Figure 14

This interface is enabled by default. Therefore, if Ethernet is connected during device installation, it will be used to connect the Gateway to the network.

You can also use the Ethernet interface to configure the device. To do this, the local network must have DHCP enabled and there must be no restrictions on the ICMP and HTTP protocols. Thus, the configuration application will be able to scan the local network and find the Gateway to configure it.

5.4 WI-FI INTERFACE

The **AirGate Geter Gateway** has an 802.11 Wi-Fi interface in the b/g/n 2.4 GHz standards, operating through an internal antenna. This interface supports WPA-Personal (PSK), WPA/WPA2, TKIP/AES/TKIP, and AES encryption.

If the Wi-Fi interface is enabled and the **AirGate Geter Gateway** is connected to a Wi-Fi network, the  LED on the front of the device will remain on. If the device is not configured, this LED will flash, indicating that the access point for configuration is open. To connect to this access point, use the SSID «TELIK GETER XXXX», where XXXX is the last 4 bytes of the Wi-Fi MAC address (located on the back label of the device).

By connecting to the access point, you can use the **Telik Geter Connect** app to configure your **AirGate Geter Gateway**.

5.5 FRONTAL USB PORT

The **AirGate Geter Gateway** has 1 USB port located at the bottom of the housing. It allows you to power a 3G/4G/5G modem. This allows you to plug in a router and use the Wi-Fi access point generated to connect the Gateway to the Internet.

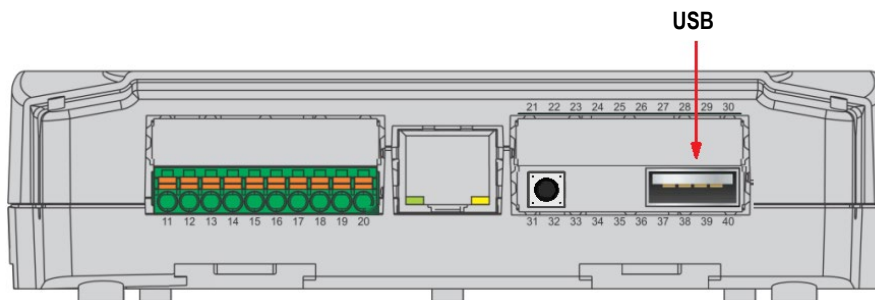

Figure 15

After configuring the USB modem beforehand, simply connect it to the Gateway port. Then, you can use **NOVUS Geter**, the configuration software of **AirGate Geter Gateway**, to connect to the modem's Wi-Fi. The **AirGate Geter Gateway** has a routine that checks the operation of the generated network. When a failure is identified, the modem plugged into the USB port will be restarted.

6 TELIK GETER SENSOR: EMBEDDED SERVICES

All **Telik Geter Sensor** embedded services are based on acceleration and temperature data. Services can be configured remotely and changed at any time through **NOVUS Geter**.

Services can be configured according to the parameters listed below.

6.1 RMS VELOCITY (MM/S)

This service shows the root mean square (RMS) value of vibration velocity. It is an algorithm used to statistically represent the average magnitude of the speed of the object being monitored by the sensor. You can set the passband. The results of this service can be used to track the evolution of the vibration in a specific machine.

Available parameters:

| PARAMETER | DESCRIPTION |
|---------------------------------|--|
| Axes | X, Y, Z, or all. |
| Sensitivity | ± 2 g, ± 4 g, or ± 8 g. |
| Resolution | 8-bits or 16-bits. |
| Sample rate | 3200 Hz. |
| Lower cutoff frequencies | 1 Hz, 2 Hz, 5 Hz, 10 Hz. |
| Upper cutoff frequencies | 500 Hz, 1000 Hz, 1600 Hz. |
| Number of samples | 32, 64, 128, 256, 512, 1024, or 2048. |
| Sampling period | 1 min, 2 min, 5 min, 10 min, 20 min, 30 min, 1 h, 2 h, 6 h, or 12 h. |
| Results per transmission | From 1 to 10 samples. |

Table 3

6.2 RMS ACCELERATION (M/S²)

This service shows the RMS value of vibration acceleration. It is an algorithm used to statistically represent the average magnitude of the acceleration of the object being monitored by the sensor. It can be used to implement vibration-based hour meters, for example.

Available parameters:

| PARAMETER | DESCRIPTION |
|---------------------------------|---|
| Axes | X, Y, Z, or all. |
| Sensitivity | ± 2 g, ± 4 g, or ± 8 g. |
| Resolution | 8-bits or 16-bits. |
| Frequencies | 0.781 Hz, 1.563 Hz, 3.125 Hz, 6.25 Hz, 12.5 Hz, 25 Hz, 50 Hz, 100 Hz, 200 Hz, 400 Hz, 800 Hz, 1600 Hz, 3200 Hz, 6400 Hz, 12800 Hz, or 25600 Hz. |
| Number of samples | 32, 64, 128, 256, 512, 1024, or 2048. |
| Sampling period | 1 sec, 2 sec, 5 sec, 10 sec, 20 sec, 30 sec, 1 min, 2 min, 5 min, 10 min, 20 min, 30 min, 1 h, 2 h, 6 h, or 12 h. |
| Results per transmission | From 1 to 10 samples. |

Table 4

6.3 STATIC INCLINOMETER (°)

This service shows the Euler angles referenced to gravitational acceleration. It is a static inclinometer that estimates the sensor's orientation based on the average of the acceleration samples collected.

Available parameters:

| PARAMETER | DESCRIPTION |
|--------------------------|---|
| Reference axis | X, Y, or Z. |
| Sensitivity | ± 2 g, ± 4 g, or ± 8 g. |
| Resolution | 8-bits. |
| Frequencies | 0.781 Hz, 1.563 Hz, 3.125 Hz, 6.25 Hz, 12.5 Hz, 25 Hz, 50 Hz, 100 Hz, 200 Hz, 400 Hz, 800 Hz, 1600 Hz, 3200 Hz, 6400 Hz, 12800 Hz, or 25600 Hz. |
| Number of samples | 32, 64, 128, 256, 512, 1024, or 2048. |
| Sampling period | 1 sec, 2 sec, 5 sec, 10 sec, 20 sec, 30 sec, 1 min, 2 min, 5 min, 10 min, 20 min, 30 min, 1 h, 2 h, 6 h, or 12 h. |

| PARAMETER | DESCRIPTION |
|--------------------------|-----------------------|
| Results per transmission | From 1 to 10 samples. |

Table 5

6.4 FAST FOURIER TRANSFORM (M/S²)

This service converts acceleration signals from the time domain to a frequency-domain representation. This algorithm shows the module of the FFT result. The result can be used for several applications. Among the most important is the analysis of failures in rotating machinery.

Available parameters:

| PARAMETER | DESCRIPTION |
|-------------------|---|
| Axes | X, Y, Z, or all. ¹ |
| Sensitivity | ± 2 g, ± 4 g, or ± 8 g. |
| Resolution | 8-bits or 16-bits. |
| Frequencies | 0.781 Hz, 1.563 Hz, 3.125 Hz, 6.25 Hz, 12.5 Hz, 25 Hz, 50 Hz, 100 Hz, 200 Hz, 400 Hz, 800 Hz, 1600 Hz, 3200 Hz, 6400 Hz, 12800 Hz, or 25600 Hz. |
| Number of samples | 32, 64, 128, 256, 512, 1024, or 2048. |
| Sampling period | 1 min, 2 min, 5 min, 10 min, 20 min, 30 min, 1 h, 2 h, 6 h, or 12 h. |

Table 6

6.5 RAW ACCELERATION (M/S²)

This service shows acceleration measurements collected at the chosen frequency. The buffer size for this function is expressed in bytes. This means that the service can return 1024 samples at 16 bits or 2048 samples at 8 bits when selecting a 2048-byte buffer.

Available parameters:

| PARAMETER | DESCRIPTION |
|---------------------|---|
| Axes | X, Y, Z, or all. ² |
| Sensitivity | ± 2 g, ± 4 g, or ± 8 g. |
| Resolution | 8-bits or 16-bits. |
| Frequencies | 0.781 Hz, 1.563 Hz, 3.125 Hz, 6.25 Hz, 12.5 Hz, 25 Hz, 50 Hz, 100 Hz, 200 Hz, 400 Hz, 800 Hz, 1600 Hz, 3200 Hz, 6400 Hz, 12800 Hz, or 25600 Hz. |
| Buffer size (Bytes) | 32, 64, 128, 256, 512, 1024, or 2048. |
| Sampling period | 1 sec, 2 sec, 5 sec, 10 sec, 20 sec, 30 sec, 1 min, 2 min, 5 min, 10 min, 20 min, 30 min, 1 h, 2 h, 6 h, or 12 h. |

Table 7

6.6 TEMPERATURE (°C)

This service shows the current sensor temperature at the selected period and resolution.

Available parameters:

| PARAMETER | DESCRIPTION |
|--------------------------|---|
| Resolution | 0.25 °C or 0.50 °C. |
| Sampling period | 1 sec, 2 sec, 5 sec, 10 sec, 20 sec, 30 sec, 1 min, 2 min, 5 min, 10 min, 20 min, 30 min, 1 h, 2 h, 6 h, or 12 h. |
| Results per transmission | From 1 to 20 samples. |

Table 8

¹ When configured for all axes, the sample limit is 1024.

² When configured for all axes, the sample limit is 1024.

6.7 TELIK GETER SENSOR: SERVICES CONFIGURATION PARAMETERS

When configuring the **Telik Geter Sensor**, you can choose the most suitable parameters for the application. All available parameters will be detailed below, according to the version of the **Telik Geter Sensor** application.

For each embedded service, you can choose a specific set of parameters.

6.7.1 ACQUISITIONS BY SUBMISSION

This parameter specifies how much data will be collected before sending in a Bluetooth Advertising (ADV). Data is not sent continuously by the **Telik Geter Sensor**, but rather in packets or ADVs. The options depend on the **Resolution** settings and the number of axes or channels chosen. RESOLUTION

The higher the value chosen for this parameter, the lower the device's battery consumption. On the other hand, using a high value impacts data latency, since data will be accumulated until the configured value is reached. Another disadvantage of using a high value for this parameter is that, if a packet is lost, a lot of data will be lost at once.

This parameter is used in almost all embedded services, except for FFT and ACCRAW services.

6.7.2 RESOLUTION

The resolution determines the number of bits used for the binary representation of the values returned by the embedded services. This parameter is used in all services. The options are: 8 or 16 bits.

If 8-bit resolution is sufficient for the application, it should be selected, as it halves the size of the data generated and, consequently, halves the energy required to send it. It also allows more measurements to be sent per ADV.

Choosing reduced resolution operation will significantly increase battery life, especially when sending large amounts of data, such as in FFT and ACCRAW services.

6.7.3 SENSITIVITY

Sensitivity is related to an accelerometer setting that determines the maximum value that can be read. This parameter is used in all services related to acceleration. The options are: (\pm) 2 g, 4 g, or 8 g, where **g** corresponds to the acceleration due to gravity (~ 9.81 m/s²).

The choice of this parameter depends on the maximum vibration level to be measured. If the behavior of the device is unknown, it is recommended to start the configuration at 8 g.

After evaluating the collected data, the appropriate value for this parameter should be verified. The lower it is, the better the resolution in amplitude of the collected signal will be.

6.7.4 AXIS

This parameter specifies which axis is of interest for a given data processing algorithm. This parameter is used in all services related to acceleration. The available options are: X, Y, Z, or ALL.

The ALL option is not available in the TILT service, since only one axis can be selected for it to operate.

6.7.5 FREQUENCY

This is the sampling frequency of the accelerometer F_s . There are several options: 0.781 Hz, 1.563 Hz, 3.125 Hz, 6.25 Hz, 12.5 Hz, 25 Hz, 50 Hz, 100 Hz, 200 Hz, 400 Hz, 800 Hz, 1600 Hz, 3200 Hz, 6400 Hz, 12800 Hz, or 25600 Hz.

Provided that the selected resolution is 8 bits, frequencies up to 200 Hz stand out for their lower energy consumption during accelerometer operation. Furthermore, choosing a high F_s is not always a good option. With very high F_s and limited N_{calc} , low-frequency signals may be poorly represented, as few complete cycles fit in the window. Therefore, F_s should be chosen according to the frequency of the signal to be measured (F_d).

A widely used metric is to use a sampling frequency between 8 and 10 times the frequency of the signal of interest (4 to 5 times the Nyquist frequency). This recommendation can be expressed by:

$$8F_d < F_s \leq 10 F_d$$

6.7.6 NUMBER OF SAMPLES

This parameter indicates how many acceleration measurement points will be used to compute the data processing algorithm in question (N_{calc}). The options are: 32, 64, 128, 256, 512, 1024, 2048, or 4096.

To set N_{calc} , it is important to define the highest frequency of the signal to be represented in the acquired data (F_d). One metric is to calculate the number of points needed to represent 3 periods of the signal of interest. This recommendation can be expressed by:

$$N_{calc} \geq \frac{3F_s}{F_d}$$

If the service to be configured is FFT, the value of can be obtained from the desired frequency resolution using the following expression:

$$N_{calc} \geq \frac{F_s}{f_{res}}$$

Although the maximum value allowed for N_{calc} is 4096 samples, this value may be limited due to the choice of other parameters. The limitation is imposed by the maximum size of the data buffer, which is 12288 bytes. The second restriction is only important for ACCRAW services, which send data vectors.

To calculate the number of bytes required in the data buffer for a given configuration (N_B), you must consider the number of active axes (E_{ax}), which can be 1 or 3 axes, and whether the resolution (R_B) is 1 or 2 bytes (8 or 16 bits), where:

$$N_B = E_{ax} R_B N_{calc}$$

Thus, N_{calc} is limited by:

$$N_{calc} \leq \min \left(\frac{12288}{E_{ax} R_B}, 4096 \right)$$

When configuring the ACCRAW service, all N_{calc} points read from the accelerometer will be sent. However, the maximum number of bytes that can be sent via the communication interface is 5,884 bytes. If N_B is greater than this limit, the excess data will not be transmitted to the Gateway.

Since FFT generates $\frac{N_{calc}}{2} + 2$ data points, this limit does not impact on the service.

6.7.7 INTERVAL BETWEEN ACQUISITIONS

It sets the sampling period for services that do not depend on the accelerometer. For algorithms related to acceleration, this value defines how often a new acceleration data collection routine will be initiated for subsequent calculation by the selected algorithm. The options are: 1 s, 2 s, 5 s, 10 s, 20 s, 30 s, 1 min, 2 min, 5 min, 10 min, 20 min, 30 min, 1 h, 2 h, 6 h, or 12 h.

The value of 1 second can only be used if the number of acquisitions per transmission is greater than or equal to 5. The value of 2 s is allowed if the number of acquisitions is greater than or equal to 2.

In addition to the restriction presented above, in services where acceleration data is used, it is necessary to verify the time required for the accelerometer to complete data collection (T_{acc}) using the following expression:

$$T_{acc} = \frac{N_{calc}}{F_s}$$

Where N_{calc} comes from the value selected in the «**Number of Samples**» parameter and F_s from the «**Frequency**» parameter. Thus, the Time between acquisitions (T_{aq}) should be set by:

$$T_{aq} > T_{acc} + T_{proc} + T_{send}$$

Where T_{proc} is the time for processing the data, T_{send} is the time for sending this data. This processing time is a maximum of 200 ms. The value of $T_{proc} + T_{send}$ is less than 1 second for most services, except for the FFT and A services. The average transfer rate for sending useful data is 380 Bps. Therefore, the delivery time in seconds for service A can be approximately by:

$$T_{send_{ACC}} \approx \frac{N_B}{380}$$

On the other hand, the approximate time for the FFT service will be:

$$T_{send_{FFT}} \approx \frac{N_B}{760}$$

Given that the FFT sends half the number of bytes collected.

In addition to the above details, the minimum T_{aq} setting for FFT and A is 30 seconds.

6.7.8 LOW AND HIGH FREQUENCY

These are the cutoff frequencies of the low-pass and high-pass filters applied to the acceleration data for calculating the RMMS. The available options are:

- **Low frequency:** 1 Hz, 2 Hz, 5 Hz, 10 Hz.
- **High frequency:** 500 Hz, 1000 Hz, 1600 Hz.

6.7.9 CHANNEL

This parameter allows you to choose the input channels to be read in a service. The available options are: A, B, or AB. When selecting option AB, both channels will be sampled simultaneously.

7 AIRGATE GETER GATEWAY: SETTINGS

To configure and provision your **AirGate Geter Gateway**, you must use the **Telik Geter Connect** application, available in versions for Windows, Linux, and Android.

The Windows and Linux versions are available in the «Support Materials» section of the **NOVUS Geter** platform (<https://novusgeter.hedro.com.br>).

The Android version is available on the Google Play Store.

The configuration starts on the **NOVUS Geter** platform, where instruction manuals are available.

8 DATA VISUALIZATION AND STORAGE VIA NOVUS GETER

Data generated by smart sensors is sent to the **NOVUS Geter**, where it is decompressed and made available on dashboards for real-time visualization. They can be stored for up to 3 years and are available to users by logging in to the platform (<https://novusgeter.hedro.com.br>). Through the platform, it is also possible to set monitoring alarms for the data collected by the sensors.

9 TECHNICAL SPECIFICATION

9.1 AIRGATE GETER GATEWAY

| OPERATION AND STORAGE CONDITIONS | AIRGATE GETER GATEWAY |
|----------------------------------|-----------------------|
| Operating temperature | -20 °C ... 60 °C. |
| Storage temperature | -5 °C ... 25 °C. |

Table 9

| COMMUNICATION INTERFACE | AIRGATE GETER GATEWAY |
|------------------------------|--|
| SouthBound | Bluetooth Low Energy 5.0. |
| NorthBound | Ethernet 10/100 Mb/s, IEEE standard 802.3, and Wi-Fi 802.11 b/g/n 2.4 GHz. |
| Cloud communication protocol | MQTT and REST. |
| RS485 | For configuration purposes only. |

Table 10

| HARDWARE | AIRGATE GETER GATEWAY |
|--------------------------|---|
| External dimensions | 142 mm x 129 mm x 38 mm. |
| Power supply | 5 Vdc or 12 ~ 24 Vdc. |
| Power supply input | Detachable terminal blocks. |
| Power output | 5 Vdc auxiliary output. |
| Communication | Bluetooth Low Energy 4.2 (2.4 GHz – External antenna) |
| Bluetooth signal range | From 50 to 70 meters without obstacles. |
| Transmission power | +8 dBm. |
| Reception sensitivity | -103 dBm. |
| Assembly | DIN rail or screw. |
| Housing | ABS + PC. |
| External antenna for BLE | SMA connector (2.4 GHz). |
| Certifications | <ul style="list-style-type: none"> • ANATEL: 13878-23-07089 • FCC: <ul style="list-style-type: none"> ○ Contains Wi-Fi module, FCC ID: 2AC7Z-ESPWROOM32D ○ Contains BLE module, FCC ID: 2ABU6-MS88SF2 • ISED: <ul style="list-style-type: none"> ○ Contains Wi-Fi module, IC: 21098-ESPWROOM32D • CE |

Table 11

9.2 TELIK GETER SENSOR

| OPERATION AND STORAGE CONDITIONS | TELIK GETER SENSOR |
|----------------------------------|--------------------|
| Operating temperature | -20 °C ... 70 °C. |
| Storage temperature | -5 °C ... 25 °C. |

Table 12

| HARDWARE | TELIK GETER SENSOR |
|---------------------|---|
| External dimensions | 25 mm x 40 mm x 40 mm. |
| Microcontroller | 32-Bit microcontroller, 16 MHz (ARM® Cortex™-M0). |
| Memory | <ul style="list-style-type: none"> • Flash memory: 256 kB. • RAM memory: 32 kB. |
| Communication | Bluetooth Low Energy 4.2 (2.4 GHz). |
| Signal range | From 50 to 70 meters without obstacles. |

| HARDWARE | TELIK GETER SENSOR |
|---|---|
| Transmission power | +4 dBm. |
| Reception sensitivity | -93 dBm. |
| Battery | 2 x ER14250 (duration 9 to 60 months, according to the application). |
| Fixing | 4 neodymium magnets 10 mm x 6 mm. |
| Encapsulation | Polycarbonate. |
| Embedded temperature sensor operation | -20 °C ... 85 °C. |
| Resolution of the embedded temperature sensor | 0.25 °C. |
| Temperature accuracy | ±4 °C without calibration. |
| Protection index | IP69K |
| Certifications | <ul style="list-style-type: none"> • ANATEL: 13848-23-07089 • FCC: FCC ID: 2AXVWN01 • CE |

Table 13

9.3 CERTIFICATIONS

ANATEL

This device is homologated by ANATEL, according to the regulated procedures for conformity assessment of telecommunications products, and meets the technical requirements applied.

This equipment is not subject to protection from harmful interference and may not cause interference with duly authorized systems.

For more information, see the ANATEL website: www.gov.br/anatel.

CE Mark

This is a Class A product. In a domestic environment, this product may cause radio interference in which case the user may be required to take adequate measures.

FCC

This equipment has been tested and found to comply with the limits for a Class A digital device, pursuant to Part 15 of the FCC Rules. These limits are

designed to provide reasonable protection against harmful interference when the equipment is operated in a commercial environment. This device generates, uses and can radiate radio frequency energy and, if not installed and used in accordance with the instructions in this manual, may cause interference in radio communications.

Any changes or modifications not expressly approved by the party responsible for compliance could void the user's authority to operate this equipment.

RF Exposure: 20 cm shall be maintained between the antenna and users, and the transmitter module may not be co-located with any other transmitter or antenna.

This device complies with part 15 of the FCC Rules. Operation is subject to the following two conditions: (1) This device may not cause harmful interference, and (2) this device must accept any interference received, including interference that may cause undesired operation.

10 WARRANTY

Warranty conditions are available on our website www.novusautomation.com/warranty.

JHB Branch

Mimic Components, Address: 5 Ramsay Street, Booyens, 2091, Johannesburg. Switchboard: +27(0)11-689-5700 | WhatsApp: 071-979-9999
PO Box 38493, Booyens, 2016, Johannesburg, South Africa. Email: info1@mimiccomponents.co.za | Website: www.mimiccomponents.co.za

Cape Branch

Mimic Cape. Address: Unit 41A, Stella Park, 57 Stella Road, Montague Gardens, 7441, Cape Town. Switchboard: +27(0)21-551-8185
WhatsApp: 071-979-9999. Po Box 36955, Chempet, 7442, Cape Town, South Africa. Email: info@mimic-cape.co.za | Website: www.mimic-cape.co.za